

Avnet's PicoZed™ SDR 2x2 is a Software Defined Radio (SDR) that combines the Analog Devices AD9361 integrated RF Agile Transceiver™ with the Xilinx Z7035 Zynq®-7000 All Programmable SoC. In a handheld form-factor PicoZed SDR provides frequency-agile wideband 2x2 receive and transmit paths in the 70 MHz to 6.0 GHz range, making it ideal for a broad range of fixed and mobile SDR applications. Integrating the critical RF signal path and high-speed programmable logic in a fully-verified system-on-module (SOM), PicoZed SDR forms the RF-to-baseband signal processing core of a wireless communications system, allowing you to focus on the differentiating features of your product. With available carrier cards for fast prototype and supported by robust simulation and code generation tools that integrate seamlessly with Xilinx Vivado® Design Suite, PicoZed SDR enables dramatic reduction in design cycles of your software-defined radio products.

FEATURES

- Fully-verified, low-power, rugged system-on-module (SOM) ready for end-product deployment
- Supported by MATLAB® and Simulink® for data streaming and Zynq targeting
- Industrial temperature rated, production-ready SOM
- Conforms to MIL-STD 202G for thermal, vibration, and shock
- **Digital Processing**
 - Xilinx Zynq XC7Z035-2L FBG676I AP SoC
 - 1 GB DDR3L SDRAM
 - 256 Mb QSPI Flash
 - microSD Card Interface
 - 10/100/1000 Ethernet PHY
 - USB 2.0 OTG ULPI PHY
 - 209 User I/O + 4 GTX channels
- **Radio Transceiver**
 - Analog Devices AD9361-BBCZ Integrated RF Agile Transceiver™
 - RF 2 × 2 transceiver with integrated 12-bit DACs and ADCs
 - Band: 70 MHz to 6.0 GHz
 - TDD and FDD operation
 - Adjustable channel BW: <200 kHz to 56 MHz
 - Supports MIMO radio: < 1 sample sync on both ADC and DAC
- Miniature RF connectors – 4 TX, 4 RX, 2 TX monitor
- Voltage regulation and sequencing with power-good failsafe circuits
- Power and signal interface through 4 micro header connectors
- Clock and frequency synthesis circuits
- Includes schematics, BOM, HDL, Linux drivers and application software

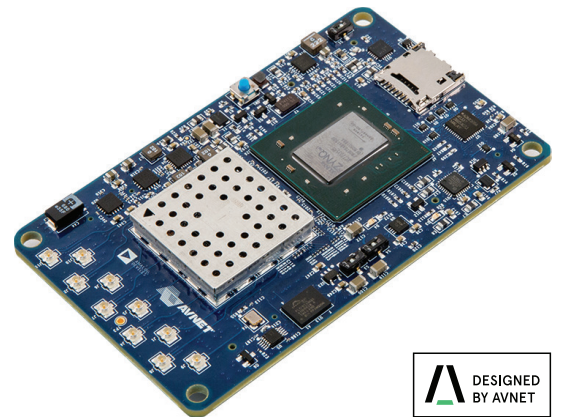

KIT INCLUDES

- PicoZed SDR 2x2 SOM (for production)

TARGET APPLICATIONS

- Portable agile wireless communications
- P25 Public Safety Radio
- Point-to-point communication
- Femtocell & picocell base stations
- Portable Instrumentation

To purchase this kit, visit www.picozed.org/sdr

BLOCK DIAGRAM

PicoZed SDR 2x2 SOM Diagram

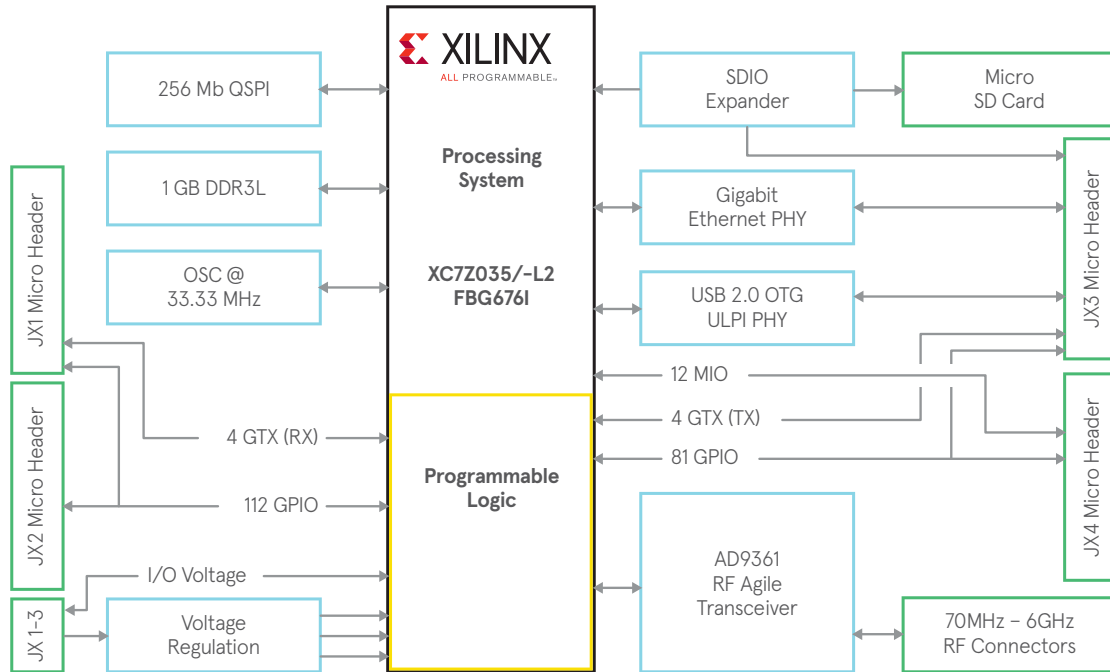

FEATURED MANUFACTURERS



PARTS

Part Number	Description	Resale
AES-Z7PZ-SDR2-G	PicoZed SDR 2x2 with Xilinx Zynq Z-7035 and Analog Devices AD9361	\$1,095 USD (1-99); \$995 USD (100+)

RELATED PARTS

Part Number	Description	Resale
AES-Z7PZ-SDR1-G	PicoZed SDR 1x1 with Xilinx Zynq Z-7020 and Analog Devices AD9364	\$549 USD (1-99); \$499 USD (1,000+)
AES-Z7PZ-SDR2-DEV-G	PicoZed SDR AD9361 Development Kit	\$1,799 USD
AES-PZSDRCC-BRK-G	PicoZed SDR Breakout Carrier	\$199 USD

Countries Available for Purchase: Americas, EMEA, Asia, Japan

CONTACT INFORMATION

North America
2211 S 47th Street
Phoenix, Arizona 85034
United States of America
eval.kits@avnet.com
1-800-585-1602

Europe
Gruber Str. 60c
85586 Poing
Germany
marketing@silica.com
+49-8121-77702

Japan
Yebisu Garden Place Tower, 23F
4-20-3 Ebisu, Shibuya-ku
Tokyo 150-6023 Japan
eval-kits-jp@avnet.com
+81-(0)3-5792-8210

Asia
151 Lorong Chuan
#06-03 New Tech Park
Singapore 556741
XilinxAPAC@avnet.com
+65-6580-6000